

# ACTIVE SOLAR SYSTEMS

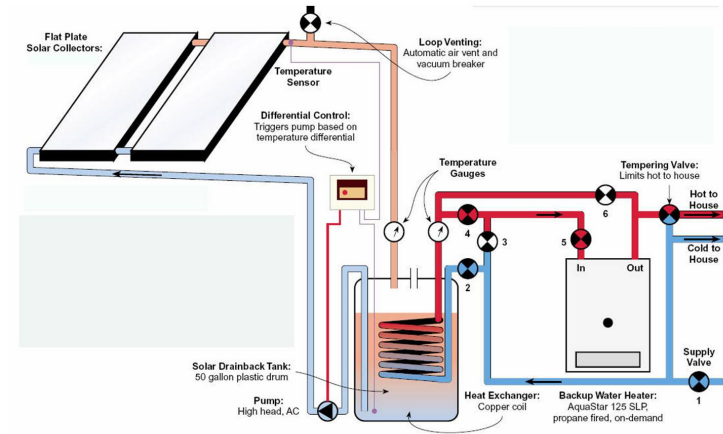

SOLAR DOMESTIC HOT WATER SYSTEM

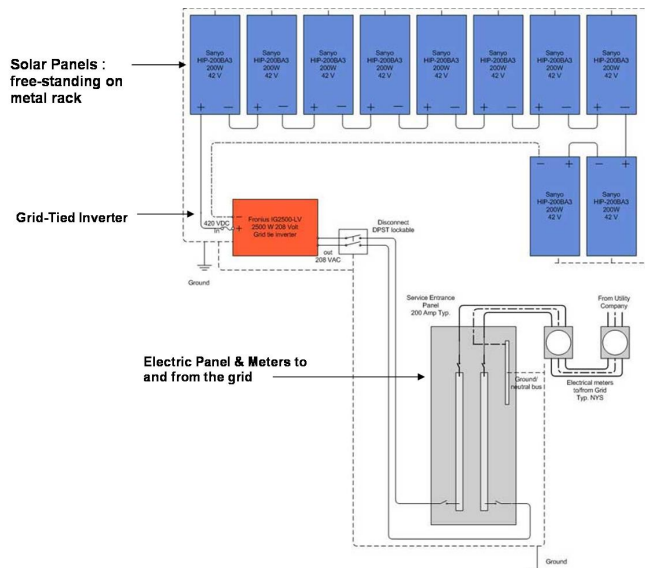
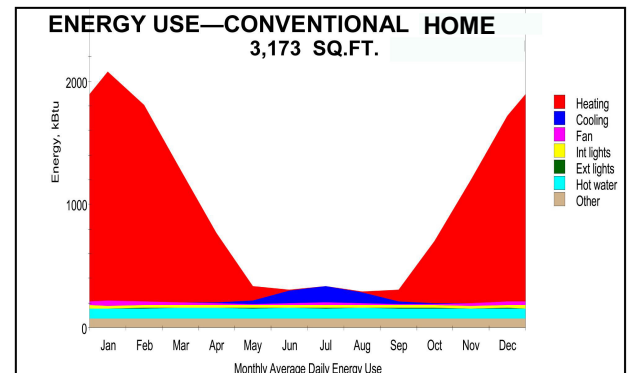
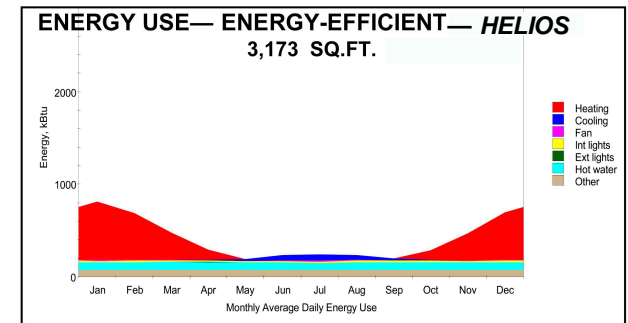

FUTURE SOLAR PHOTOVOLTAIC — GRID TIED SYSTEM

The solar domestic hot water system saves 75 percent of energy compared with a conventional electric system.

A future solar photovoltaic grid-tied system will be mounted on a metal frame on the southern slope below the home, and will be sized to provide 50 percent of electrical needs.